

APPLICATION NOTE

SIDE MOUNTING
 1 EPM: BOLT PATTERN [A, C, E] OR [B, C, D] OR [A, B, D, E].
 2-3 EPMS: BOLT PATTERN [A, B, D, E] MINIMUM. BOTH EXTERIOR STACKS MUST BE BOLTED AND SUPPORTED.
 4-6 EPMS: ALL POSITIONS [A, B, C, D, E] MUST BE INSTALLED.
 MORE THAN 6 EPMS: A MID-PLATE SUPPORT MUST BE USED EVERY 6 EPMS.

TOP MOUNTING
 ALL 4X M3 SCREWS MUST BE INSTALLED A MINIMUM OF 12 MM.

CABLE ENTRY OPTIONS

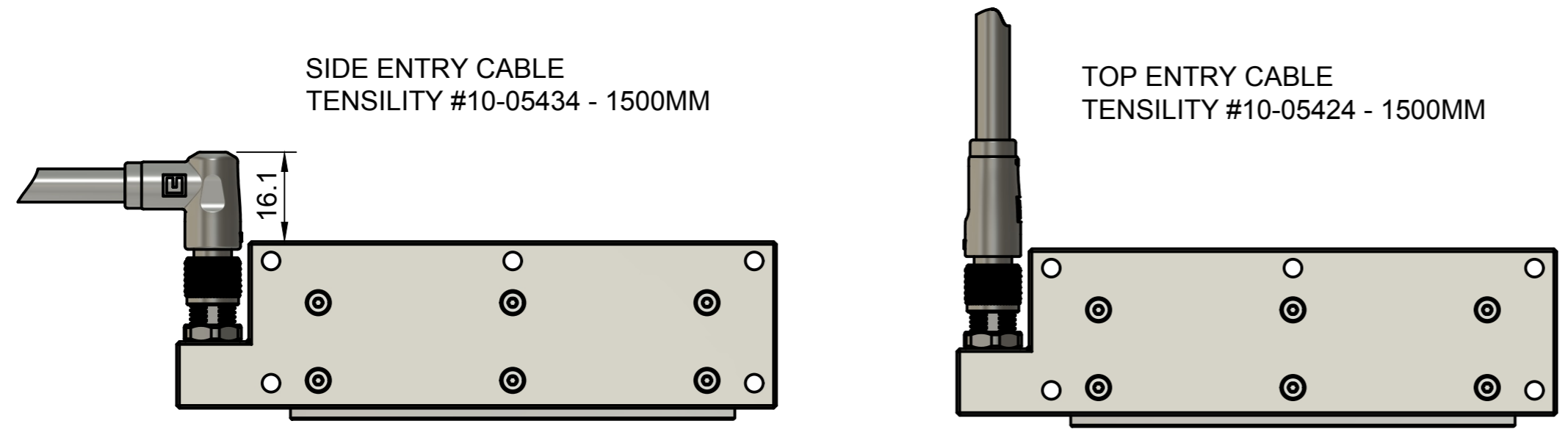

250G-CLASS MOUNTING AND CABLE ROUTING DATASHEET

Dept.	Technical reference	Created by D. CHOU	6/13/25	Approved by F. JOHNSON	6/15/25
MASS: 250g		Document type PUBLIC RELEASE	Document status NON-CONFIDENTIAL		
		Title EPMC-250G-31D-394BA THE ELECTRO-PERMANENT MAGNET COMPANY ELECTROPERMANENTMAGETS.COM	DWG No. 250G CLASS BASELINE		
Rev. C	Date of issue 7/3/2025	Sheet 1/1			